

(No Model.)

2 Sheets—Sheet 1.

E. R. HYDE & A. VALLENTINE.

GRINDING MACHINE.

No. 375,821.

Patented Jan. 3, 1888.

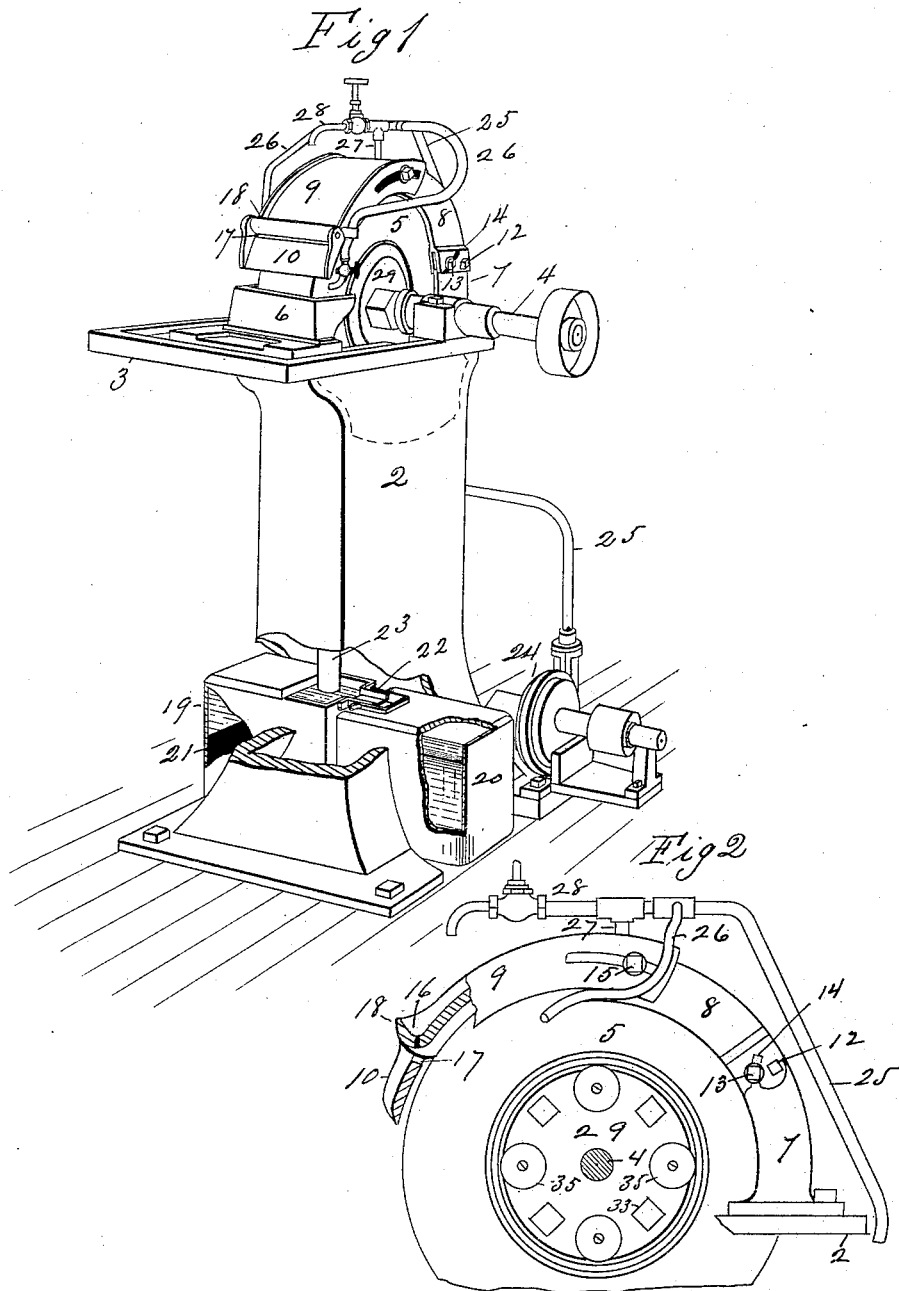

Witnesses.
L. M. Chamberlain.
Herbert S. Nelson

Inventors.
E. R. Hyde
Arthur Valentine
By Chapman & Co
Attys

UNITED STATES PATENT OFFICE.

ELWIN R. HYDE AND ARTHUR VALLENTINE, OF SPRINGFIELD, MASSACHUSETTS, ASSIGNORS TO THE SPRINGFIELD GLUE AND EMERY WHEEL COMPANY, OF SAME PLACE.

GRINDING-MACHINE.

SPECIFICATION forming part of Letters Patent No. 375,821, dated January 3, 1888.

Application filed December 13, 1886. Serial No. 221,366. (No model.)

To all whom it may concern:

Be it known that we, ELWIN R. HYDE and ARTHUR VALLENTINE, citizens of the United States, residing at Springfield, in the county of Hampden and State of Massachusetts, have invented new and useful Improvements in Grinding-Machines, of which the following is a specification.

This invention relates to grinding-machines, and pertains to that class thereof in which emery-wheels are used for grinding; and the invention consists in the construction and arrangement of the various parts of the machine, all as hereinafter fully described, and set forth in the claims.

In the drawings forming part of this specification, Figure 1 is a perspective view of an emery-wheel grinding-machine embodying our improvements, a portion of the stand thereof and of water-boxes thereunder being broken away to better illustrate certain constructions hereinafter described. Fig. 2 is a side elevation of a portion of the grinding-wheel and of the devices on one side thereof by which it is supported on its shaft, the hood covering part of the wheel (a portion of the side of which hood is shown broken away) and of the water-supply pipe which conducts water onto the hood and onto the wheel. Fig. 3 is a transverse section of the grinding-wheel and its hangings, together with a portion of the shaft thereof. Fig. 4 is a side elevation of one of the side plates of the grinding-wheel hanging devices, showing the heads of the clamping-bolts thereon. Fig. 5 is a plan view, and Fig. 6 a transverse section, (somewhat enlarged,) of the wheel-balancing cups, which are secured to the sides of said side plates.

In the drawings, 2 is the hollow standard of the grinding-machine, having a table, 3, projecting horizontally from one side thereof to hold work that is being operated upon, and the upper end of said standard is provided with suitable bearings, in which the shaft 4 runs, on which is hung the grinding-wheel 5. The upper end of the standard is provided with a wheel-cup, which is outlined in dotted lines in Fig. 1, in which the lower part of the wheel runs and which serves to catch the water as it runs from the wheel, together with

emery particles and metal, which are the results of the grinding action of the machine.

To the rear side of the upper end of the standard 2 is attached a metallic hood, which nearly covers the periphery and portions of the sides of the wheel near the latter, as shown in Figs. 1 and 2—that is to say, said hood covers the aforesaid portion of the periphery of the wheel nearly which is above the top of the standard. Opposite the front edge of the wheel on the table 3 is set a guard, 6, against which work is held or balanced to properly guide it when applying it to the emery-wheel, and the front end of said hood terminates a little way above said guard, as shown in Fig. 1. The said hood consists of four sections, 7, 8, 9, and 10. Said section 7 is bolted to the upper end of the standard 2. Section 8 is pivoted to section 7 by a bolt, 12, in opposite sides of the sections, and its lower end is slotted to inclose the upper ends of section 7, and the lower end of the sides of section 8 is provided with a slot, 14, through which a bolt, 13, passes into section 7. By loosening the bolt 13 the upper end of section 8 can be swung toward and from the periphery of the grinding-wheel 5, and thereby be made to occupy the same position relative to the latter, whether the wheel be of full size or worn to a smaller diameter, and when so adjusted the section 8 is held in said adjusted position by screwing up the bolt 13. The sides of section 9 are slotted, as shown, and the rear end of said section is applied over the upper end of the section 8, and through the said slots in section 9 bolts 15 are put into section 8. The said slots in section 9 of the hood and its bolt-connection with section 8 provide for moving section 9 longitudinally over the top of the wheel and for swinging its unconnected end to adjust said section to the varying size of the grinding-wheel, so that it shall occupy the same position relative to said wheel, whether it be of full diameter or more or less worn by grinding, the desirable position of the hood-sections over the wheel being one in which the borders lap over the sides of the wheel, and in which the periphery is properly covered while the wheel is running, to prevent water and emery from being thrown there-

from by centrifugal force. The unconnected end of section 9 has a water-trough, 16, formed in its lower end, and to said lower end is pivoted the hood-section 10, through which is formed a water-passage, 17, to permit water which runs over the upper edge, 18, of said water-trough to run through said water-passage onto the grinding-wheel beneath the hood. Said section 10 of the hood is pivoted to section 9, so that it can, when desired, be swung upward against the top of the latter and uncover more of the edge of the wheel than is left exposed between section 10 and the guard 6, as shown in Fig. 1. The bottom of trough 16 is perforated, as shown, to permit more or less water therefrom to drip directly onto the grinding-wheel. The means for supplying water to said water-trough 16 on the hood and to the sides of the grinding-wheel, and for conveying the water and the metallic and emery-wheel substances from the said wheel-cup under the wheel, and for separating said substances from the water, so that the latter may be used over and over in a comparatively pure state, or one that is free from said substances, are peculiarly adapted to grinding-machines of this class, and their construction and arrangement are as follows:

At the lower end of the standard 2, partly within and partly without the latter, as shown in Fig. 1, are located two water-boxes, 19 and 20, the top of the latter being slightly lower than the top of box 19, and on the latter is provided a trough, 22, through which water which overflows from box 19 runs into box 20. A water-pipe, 23, is connected in the lower side of the said wheel-cup, and serves to convey water and the said metallic and emery-wheel substances from said wheel-cup into box 19, where said substances, being of a heavy nature, settle in the bottom of said box, as indicated at 21, Fig. 1, thereby leaving the water comparatively clear, and the latter overflows through trough 22 into box 20. The said substances 21 are from time to time taken out of box 19 by removing the cover thereof.

A rotary or other suitable pump, 24, is located near the water-box 20 and is operated by suitable connection with the grinding-machine, and has a suction-pipe connected with the water-box 20, and a discharge-pipe, 25, is connected to said pump and extends upward on the rear side of the machine to a point above the said hood-sections above the grinding-wheel, as shown in Figs. 1 and 2. To the upper end of the pipe 25 are attached two branch pipes, 26, which lead to the opposite sides of the grinding-wheel 5 near its front edge, and each is provided with a stop-cock to regulate the flow of water against the sides of the wheel. In Fig. 2 the said stop-cock is not shown on the branch pipe 26. The end of the pipe 25 and its connections are supported over the hood-sections by a piece, 27, which rests on the latter. A pipe, 28, a continuation of pipe 25, extends forward over the hood-section

9, to convey water to the trough 16 in the latter, and has a suitable stop cock therein, as shown.

By means of the above-described water-connections it is seen that the grinding-machine, when used for wet grinding, is supplied with water from the box 20, into which, from time to time, water is put to keep a sufficient supply therein, and the water from the wheel-cup under the wheel, which is received by the box 19, is in the latter drained of its heavy substances, as aforesaid, and is thereby made fit for being used over and over on the wheel. By means of said water-supply devices each grinding-machine contains within itself means for keeping the grinding-wheel supplied with water, and the necessity of conveying water to the machine by pipe-connections from other sources is obviated and no waste-pipe has to be connected to the machine to convey the water from the wheel-cup to a suitable drain.

The hood-section 10 may be omitted when it becomes desirable to expose more of the wheel above the guard 6.

As aforesaid, the emery grinding-wheel 5 is hung on the shaft 4 between two circular side plates, 29, and the grinding-wheel is made with a single circular perforation, 30, a little less in diameter than said side plate. On each side of the grinding-wheel, slightly removed from the border of said perforation 30, a projecting annular ring, 31, is formed, the outside of which is beveled or inclined, as shown in Fig. 3. On the inner side of each of said side plates is formed an annular groove, 32, of corresponding form to the said annular ring 31, and the side plates are fitted against the opposite sides of the wheel and engaging with said rings 31, and they are bolted together in that position firmly against the sides of the wheel by the bolts 33, which pass transversely through the said perforation in the wheel. The wheel provided with the said rings 31 on its opposite sides and the side plates having annular grooves inclosing said rings are features of construction which serve to prevent the wheel from breaking and flying in pieces when running under the great centrifugal strain to which the wheel is subjected.

To provide means for balancing the wheel after it is clamped between the side plates, 29, the latter are provided with a series of sockets or indentations, 34, into each of which is fitted an inverted cup, 35, and said cups are secured to the side plates by a central screw, 36. When the wheel and shaft are ready to be hung on the grinding-machine, they are hung on the centers of a lathe in the usual way, and the wheel is slowly turned by hand and then released to ascertain which side thereof is heaviest, and any slight overweight on the wheel to one side of the shaft is counterbalanced by putting lead or other similar heavy substance into one of the cups 35, or into more of them, as may be required to balance the wheel, and the cup containing said balancing substance is secured on the side plate, as shown in Fig.

4. Only one of said side plates is shown in the drawings as provided with the balancing-cups 35; but both side plates may be fitted therewith, if desired.

5 What we claim as our invention is—

1. In a grinding-machine, a wheel-hood nearly covering that part of the periphery of the grinding-wheel above the wheel-shaft and a portion of the opposite sides of the wheel adjoining said part of the periphery, consisting of the hood-sections 7, 8, 9, and 10, section 7 being rigidly secured to the machine, section 8 pivoted to section 7, section 9 pivoted to and having a longitudinally-sliding motion on section 8, and the section 10 pivoted to the free end of section 9, substantially as set forth.

2. The section 9 of the wheel-hood having the water-trough 16 in its lower end, combined with the hood-section 10, pivoted to and pend-

ing from the end of section 9, and having the water-passage 17 through it, substantially as set forth.

3. In a grinding-machine, a wheel-hood nearly covering that part of the periphery of the grinding-wheel above the wheel-shaft and a portion of the opposite sides of the wheel adjoining said part of the periphery, consisting of the hood-sections 7, 8, and 9, section 7 being rigidly secured to the machine, section 8 pivoted to section 7, and section 9 pivoted to section 8, substantially as set forth.

ELWIN R. HYDE.
ARTHUR VALLENTINE.

Witnesses:

G. M. CHAMBERLAIN,
H. F. ASHTON.